

# CUBE Switch Module PRO

Change every switch in the world to be a smart one



LifeSmart云起

让每一个家庭成为智能家庭

# CUBE Switch Module PRO

Change every switch in the world to be a smart one



## Upgrade to smart switches

Make all normal switches intellectual



## Voice control

Support smart speakers to control switches

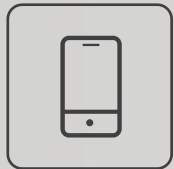

## Remote control

Control the lights in anywhere & anytime



## Scenes linkage

Open/close according to preset scenes



## Timed task

On/off regularly, live a regular life

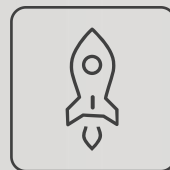

## Performance upgrade

Increase load capability, add 3-way switch



# Normal switches turn into smart ones instantly

Suitable for all 86 type panel cases, work with all main switch brands



86 Type

**CHINT**  
CHINT GROUP

  
**BULL公牛**  
BULL

  
**legrand**  
LEGRAND

**SIEMENS**  
SIEMENS

**HONYAR**  
HONYAR

**ABB**  
ABB

**Panasonic**  
Panasonic

  
**Shlinorde**  
Shlinorde

  
**DELIXI**  
DELIXI

# Mobile, voice & scene link multiple control ways, turn on devices whether sitting or lying

## Remote control

LifeSmart APP displays real-time switch statuses, controls on/off statuses of lights in anytime & anywhere

## Timed task

Set switches regularly on/off through LifeSmart APP



## Voice control

Supports voice control platforms like Amazon Echo, Google Home, 小爱同学, 小度在家, 天猫精灵, 腾讯云小微, 百度度秘, iFLYTEK, Mobvoi, Rokid and so on



## Smart scenes

Link with other smart devices, enjoy coziness and convenience of smart life in every moment.

\*Need to work with smart stations



\*需搭配其他智能设备使用



CUBE Switch Module PRO

CUBE Switch Module

# Differences?

● Size & shape

Load & performance ●

## ● Size & shape

Still keeping **Delicate Shape**

Slightly differs in sizes

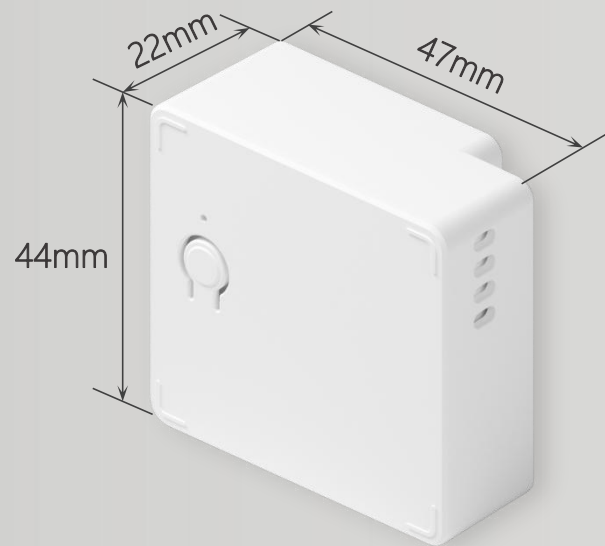

1-way

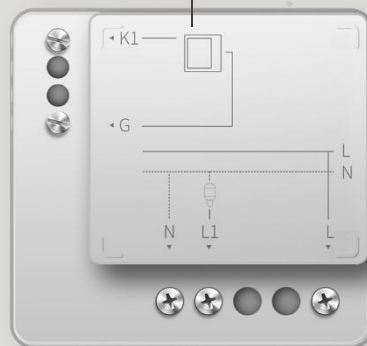

2-way

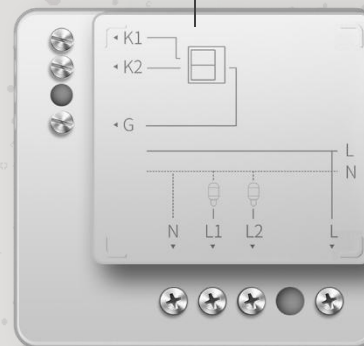

3-way

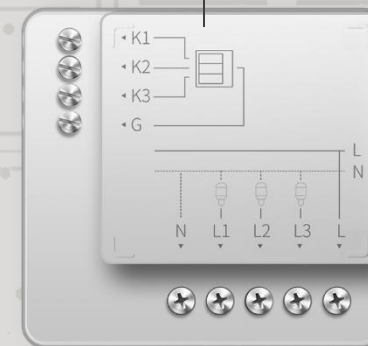

Add **3-Way** switch control module

More selections

● Size & shape

# 1-way

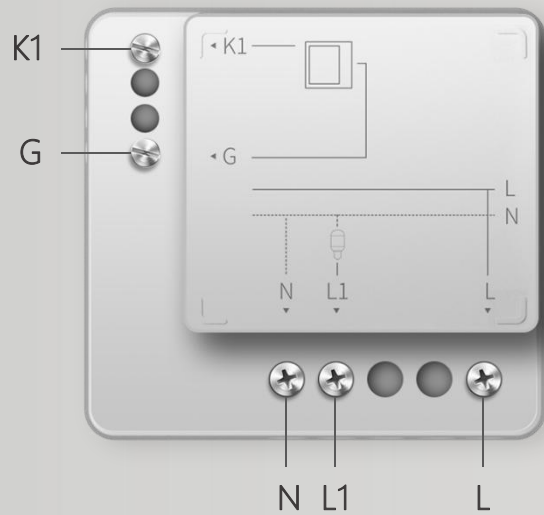

N: Neutral wire IN  
 L: Live wire IN  
 L1: 1<sup>st</sup> live wire OUT  
 K1: 1<sup>st</sup> switch control wire IN  
 G: Public wire of the switch panel IN

# 2-way

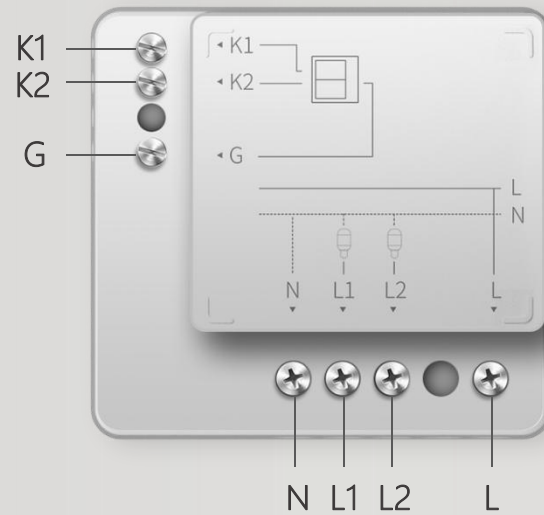

N: Neutral wire IN  
 L: Live wire IN  
 L1: 1<sup>st</sup> live wire OUT  
 L2: 2<sup>nd</sup> live wire OUT  
 K1: 1<sup>st</sup> switch control wire IN  
 K2: 2<sup>nd</sup> switch control wire IN  
 G: Public wire of the switch panel IN

# 3-way

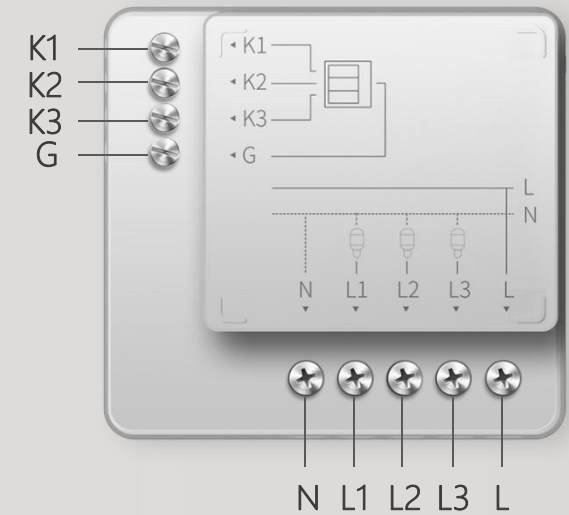

N: Neutral wire IN  
 L: Live wire IN  
 L1: 1<sup>st</sup> live wire OUT  
 L2: 2<sup>nd</sup> live wire OUT  
 L3: 3<sup>rd</sup> live wire OUT  
 K1: 1<sup>st</sup> switch control wire IN  
 K2: 2<sup>nd</sup> switch control wire IN  
 K3: 3<sup>rd</sup> switch control wire IN  
 G: Public wire of the switch panel IN

# Load & performance

300W single channel resistive load



**500W** single channel resistive load

150W single channel capacitive & inductive load

More powerful load

**200W** single channel capacitive & inductive load

Prevents switch sticking

Magnetic latching relay: 8A



**16A**

CUBE Switch Module



CUBE Switch Module PRO



Control more powerful lights





# Managing sockets, can work with small power **electrical appliance**

Electric fan, air cleaner...

TV, set-top box...

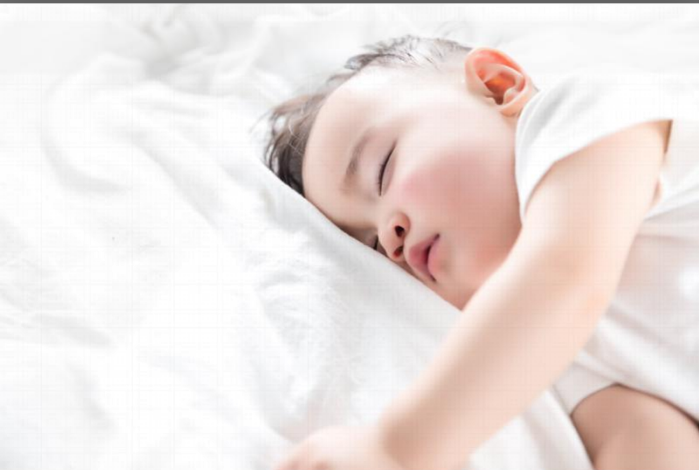

Control electric fans, air cleaners

Times ON/OFF

A cozy living environment



When adults are out

Turn off TV, STB sockets

Keeps children's minds on studying



# SMART HOME



# King of Aftermarket Installed Products



# Specifications

Model	LS191/LS192/LS193
Size	47(L)×22(W)×44(H)mm
Material	PC
Colour	Ivory white
Working Temperature	-5~45°C
Working Humidity	5~90%
Working Voltage	100-240V AC
Power	< 0.3W
Wireless Protocol	CoSS
Wireless Frequency	433MHz
Wireless Distance	100m (Open field)
Max load	500W single channel resistive load, 200W single channel capacitive & inductive load
Relay	16A magnetic latching relay