

# LifeSmart 窗帘电机智控器简易说明书

Typical Graphic Layout | Scale: 1/1

尺寸	60*60mm
纸张	80g书纸
工艺	

正面

**LifeSmart®**  
Simply Brilliant

**MINS Curtain Motor Controller**  
User Guide v1.0

## PRODUCT INSTRUCTION

LifeSmart MINS Curtain Motor Controller can be combined with a traditional curtain motor to upgrade it to a smart curtain motor. It is small, easy to install, and does not require wall wiring. It's powered by batteries and works independently without external power. It can be applied to curtain motor of various specifications.

MINS Curtain Motor Controller supports two-way communication and smart phone control. Users can control the curtain motor anytime and anywhere via mobile phone, set timing tasks, and

## PRODUCT INSTRUCTION

participate in smart scenes such as opening curtains when you're home, closing the curtains automatically when you leave home with other smart devices (Motion Sensors, Door/Window Sensors, etc.).

## SPECIFICATIONS

<b>Size</b>	135*32*23mm
<b>Weight</b>	55g (battery excluded)
<b>Material</b>	PC+ABS
<b>Battery</b>	AA LR6x2
<b>Operating temperature</b>	-5~45°C
<b>Operating humidity</b>	5~90%
<b>Communication protocol</b>	CoSS
<b>Wireless frequency</b>	433MHz
<b>Wireless distance</b>	100m (open field)

## BUTTON & INTERFACE

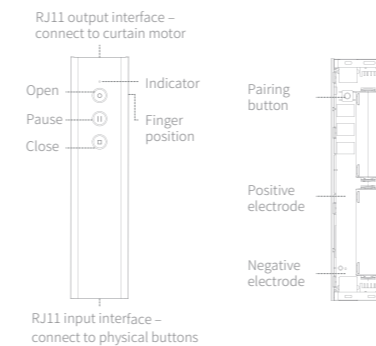

## INTERFACE DEFINITION

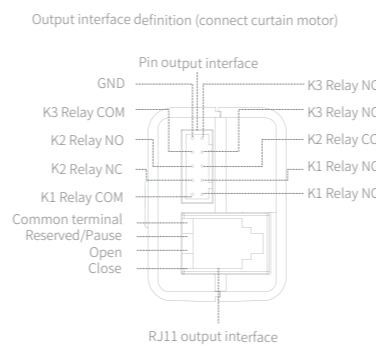

## INTERFACE DEFINITION

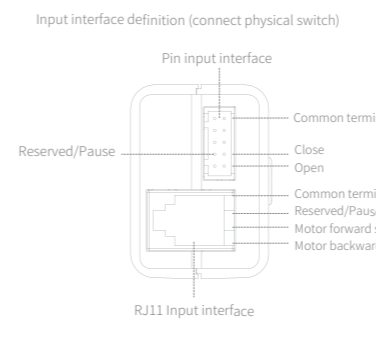

## INTERFACE

This cable is suitable for Dooya electric curtain motor. For other specifications or brands, please refer to their user guide to purchase the corresponding cable. When the pairing is completed, please select the working mode according to the interface definition of your curtain motor in the App. When the second line is RESERVED, select the two-line mode; when the second line is PAUSE, select the three-line mode.



## INSTALLATION INSTRUCTION

LifeSmart's MINS Curtain Motor Controller must be paired with Smart Station to work in the smart home system.

- Open the battery back panel of MINS curtain motor controller from the side and put batteries in;
- After configuration of the Smart Station, click "+" on the home page of the App, then click "Add New Device", select "MINS Curtain Motor Controller" to enter the pairing mode;

## INSTALLATION INSTRUCTION

- Press and hold the pairing button for more than 5 seconds until the indicator light flashes. Enter the pairing state, click "Start Pairing";
- Follow the instructions on App and complete the pairing operation;
- If pairing is not successful, repeat steps 2-4 until the pairing is successful;

反面

## INSTALLATION INSTRUCTION

- Install the battery back panel, connect MINS curtain motor controller to the curtain motor through the RJ11 output interface (please make sure that the cables are in right order). Operate the motor on the product buttons and App to test whether it functions properly;

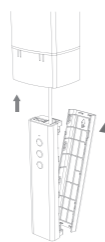

## INSTALLATION INSTRUCTION

- (Optional) If there is a physical switch, connect the RJ11 input interface to the physical switch;

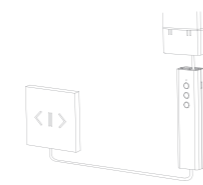

- MINS curtain motor controller can set timer tasks, trigger smart scenes and so on. Please explore more on LifeSmart App.

## IN YOUR PACKAGE

- MINS Curtain Motor Controller 1
- AA LR6 Battery 2
- RJ11 Cable 1
- User Guide 1

## WARRANTY DESCRIPTION

User support e-mail address  
[support@ilifesmart.com](mailto:support@ilifesmart.com)  
Website  
[www.ilifesmart.com](http://www.ilifesmart.com)



## WARRANTY DESCRIPTION

Thank you for purchasing this LifeSmart product. In order to protect your rights, please read the following content carefully: The warranty period of our company's products is one year from the date of purchase or longer if local laws impose a longer minimum term, in which case the minimum term is the warranty period. During the warranty period, any faults caused by the product itself or for quality problems that arise under normal usage, LifeSmart will provide a free replacement.

## ATTENTION

The following conditions are not covered by the warranty:

- Product failure or damage caused by installation, use, and maintenance that is not in accordance with the product instructions;
- Products beyond the warranty period;
- Products that have the barcode tampered with or removed;
- Devices that have been tampered with or customized outside of LifeSmart Terms Of Service as on the LifeSmart APP and website;

## ATTENTION

- User-caused damage, such as inappropriate voltage input, high temperature, accidental spillage, physical damage, etc.;
- Product failure or damage caused by force majeure such as earthquakes, fires, or floods;
- Product failure or damage caused by other problems except the product itself.

## DECLARATION

LifeSmart is a trademark of Hangzhou LifeSmart Technology Co., Ltd. As for the trademarks, product logos and product names from other companies presented within this manual, they are possessed by their own right holders. Without our written permission, no entity or individual shall extract, copy or disseminate in part or the whole of the manual contents in any form. Due to product version upgrades or other reasons, content of this manual may change. Our company reserves the right to change the contents of this manual without any notice.

## DECLARATION

This manual is used only for instructional purposes. We strive to provide accurate information in this manual, but we are not able to ensure that the content of this manual is current. Statements, information and advice in this manual do not constitute any expressed or implied assurance. Updated manuals are available on our website at [www.ilifesmart.com](http://www.ilifesmart.com) or by contacting our team.

## DECLARATION

Manufacturer: Hangzhou LifeSmart Technology Co., Ltd.  
Address: 10-11th Floor, Building A, SUPCON Information, 352 Binkang Road, Binjiang District, Hangzhou, Zhejiang, CHN



Facebook: [ilifesmarthome](https://www.facebook.com/ilifesmarthome) Twitter: [ilifesmarthome](https://twitter.com/ilifesmarthome)

Copyright © 2019 LifeSmart Inc. All Rights Reserved. PIN:8800XXX0 A0